

HDBase-T Slim-Line Transmitter/Receiver Set



Receiver



Transmitter



Transmitter Back



Receiver Back

EHB-100

USER MANUAL v1.0



Table of Contents

- Introduction 2
- Features 2
- Package..... 2
- Specifications 3
- Operation Controls & Functions 4-5
- Application Examples 6-7
- Preparing RS232 Cable 8-9
- RS 232 Application Example 10
- Warranty 11
- Safety Information 11

EHB-100

Introduction

This HDBaseT transmitter/receiver set can extend HDMI over a single CAT5e/6/6A cable. This product offers Bi-directional IR, RS-232 and Bi-directional PoC making any professional A/V set-up more efficient and easy to use. Uncompressed video and audio can be transmitted up to 230ft/70m. This design of HDBaseT™ technology allows for full usage of HDMI and controls over CAT5e/6/6A cable.

Features

- HDMI 1.4b, HDCP 2.2 and 1.4
- Video resolutions up to 4K2K@30Hz
- Audio up to 7.1 channels of High Definition audio pass through (LPCM, Dolby TrueHD, and DTS-HD Master Audio).
- Supports HDMI High Bit Rate (HBR) audio pass through
- POC (Power Over Cable) functionality is supported, either TX or RX is powered by a 24V@1A power supply. POC Power consumption is less than 10W.

See application example1 (pg. 6)

- Transfer Bidirectional RS-232 control signal together with the HDMI signal.

See application example 2 (pg. 6)

- Transmission distance: Over CAT6 cable
70 meters: 1080P @60Hz36bit; 3D1080P@30Hz36bit;
40 meters: 1080P @60Hz@48bit; 1080P @120Hz@24bit; 3D1080P@60Hz@36bit; 4K x 2K@30Hz@24bit.

See application example 3 (pg. 7)

Bidirectional RS232 Control Application Example

Package Contents

- HDMI Extender Transmitter - (1x)
- HDMI Extender Receiver - (1x)
- 24V1A DC Power Supply - (2x)
- Wideband IR Emitter - (2x)
- Wideband IR Receiver - (2x)
- Mounting Brackets - (4x)
- 3pin Screw Terminal Plug - (2x)
- Operation Manual - (2x)



EHB-100

Technical Specifications

Technical	
HDMI Compliance	HDMI 1.4b
HDCP Compliance	HDCP 2.2 and HDCP 1.4
Video Bandwidth	297MHz [10.2Gbps]
Video Resolutions	up to,4K2K@30Hz,1080P@120Hz, and 1080P 3D@60Hz
Color Space	RGB, YCbCr 4:4:4, YCbCr 4:2:2
Color Depth	10-bit, 12-bit
HDMI Audio Formats (Pass-through)	LPCM 2/5.1/7.1CH, Dolby Digital, DTS 5.1, Dolby Digital+, Dolby TrueHD, DTS-HD Master Audio, Dolby Atmos, DTS:X
ESD Protection	Human body model - +/- 8kV (air-gap discharge) & +/-4kV (contact discharge)
Transmitter Connections	
Inputs	1xDC Power In 1x HDMI Type A [19-pin female] 1x RS232 [Screw Terminal] 1x IR Receiver
Outputs	1x HDBaseT In [RJ45] 1x IR Emitter
Receiver Connections	
Inputs	1xDC Power In 1x HDBaseT In [RJ45] 1x RS232 [Screw Terminal] 1x IR Receiver
Outputs	1x HDMI Type A [19-pin female] 1x IR Emitter
Mechanical	
Housing	Metal Enclosure
Color	Black
Dimensions	65mm [W] x 115mm [D] x 17mm [H]
Weight	200g
Power Supply	Input: AC100 - 240V 50/60Hz Output: DC 24V/1A (US/EU standards, CE/FCC/UL certified)
Power Consumption	6W (Max)
Operation Temperature	32 - 104 °F / 0 - 40 °C
Storage Temperature	-4 - 140°F / -20 - 60°C
Relative Humidity	20 - 90% RH (no condensation)

EHB-100

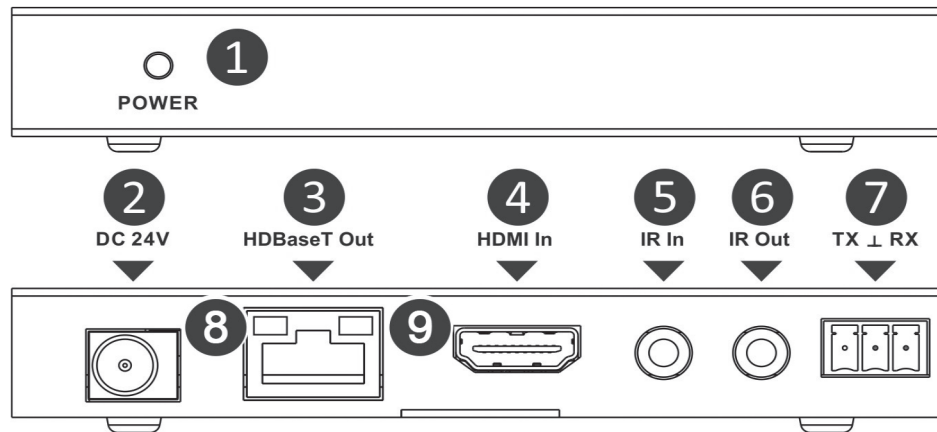

Operation Controls and Functions

Transmitter

1. POWER: This LED illuminates when the device is connected with power supply.
2. DC 24V: Plug the 24V DC power supply into the unit.
3. HD BaseT OUT: Standard HD BaseT signal output port. Connect HD BaseT receiver with a category cable following the standard of direct interconnection method.
4. HDMI IN: HDMI input port. This slot is where you connect the HDMI source.
5. IR IN: Channel 2 IR Receiver. Connect with Wideband IR Rx.
6. IR OUT: Channel 1 IR Transmitter. Connect with Wideband IR Tx.
7. RS232: Phoenix jack provide Serial port control signal from receiver or to receiver.
8. Connection Signal Indicator Lamp
 - *Illuminate: The Transmitter and Receiver are in good connections status.
 - *Flashing: The Transmitter and Receiver are in poor connections status.
 - *Dark: The Transmitter and Receiver are not connected.
9. Data Signal Indicator Lamp
 - *Illuminate: The HDMI signal with HDCP.
 - *Flashing: The HDMI signal without HDCP.
 - *Off: No HDMI signal.

EHB-100

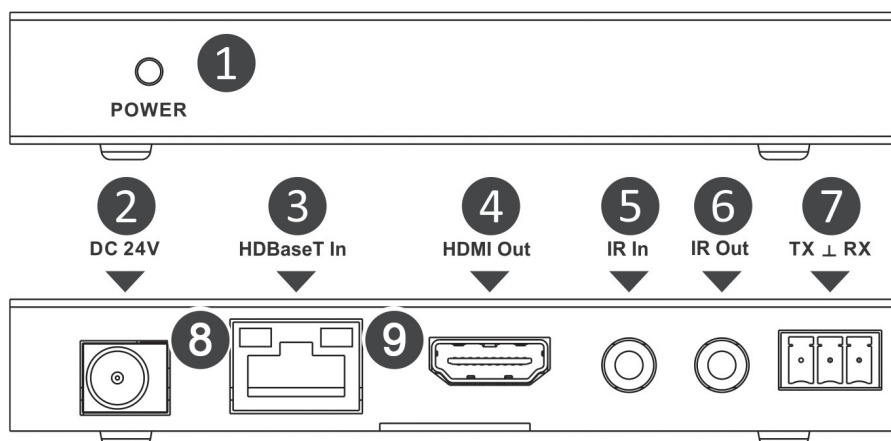

Operation Controls and Functions

Receiver

1. POWER: This LED illuminates when the device is connected with power supply
2. DC 24V: Plug the 24V DC power supply into the unit.
3. HD BaseT IN: Standard HD BaseT signal input port. Connect HD BaseT transmitter with a category cable following the standard of direct interconnection method.
4. HDMI OUT: HDMI output port. This slot is where you connect the HDTV or monitor with HDMI cable.
5. IR IN: Channel 1 IR Receiver. Connect with Wideband IR Rx.
6. IR OUT: Channel 2 IR Transmitter. Connect with Wideband IR Tx.
7. RS232: Phoenix jack provide Serial port control signal from receiver or to receiver.
8. Connection Signal Indicator Lamp
 - *Illuminate: The Transmitter and Receiver are in good connections status.
 - *Flashing: The Transmitter and Receiver are in poor connections status.
 - *Dark: The Transmitter and Receiver are not connected.
9. Data Signal Indicator Lamp
 - *Illuminate: The HDMI signal with HDCP.
 - *Flashing: The HDMI signal without HDCP.
 - *Off: No HDMI signal.

EHB-100

Application Example 1

POC (Power Over Cable) Application Example

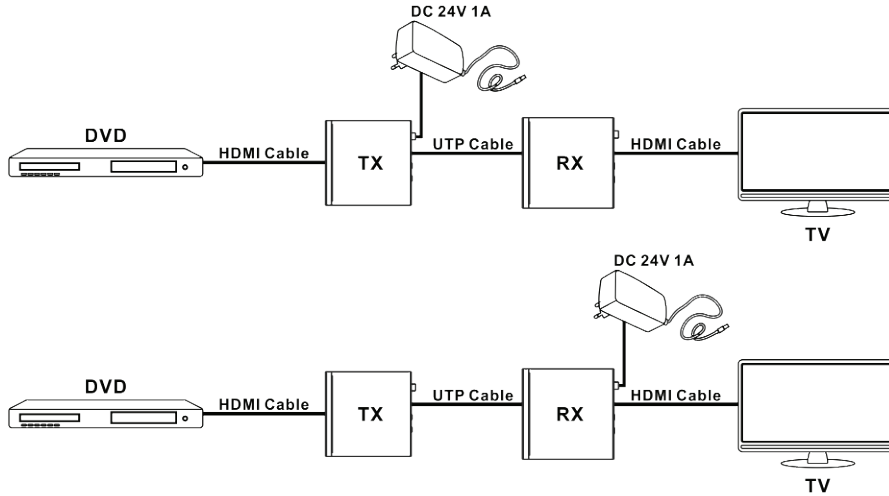

Application Example 2

Bidirectional Infrared Control Application Example

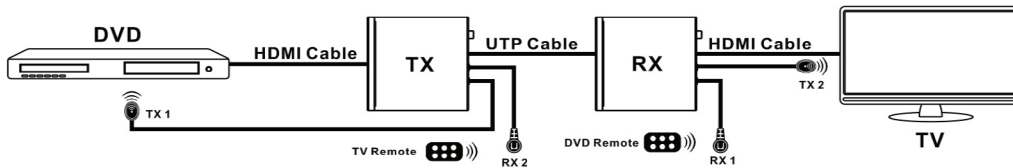

Application Example 3

Bidirectional RS232 Control Application Example

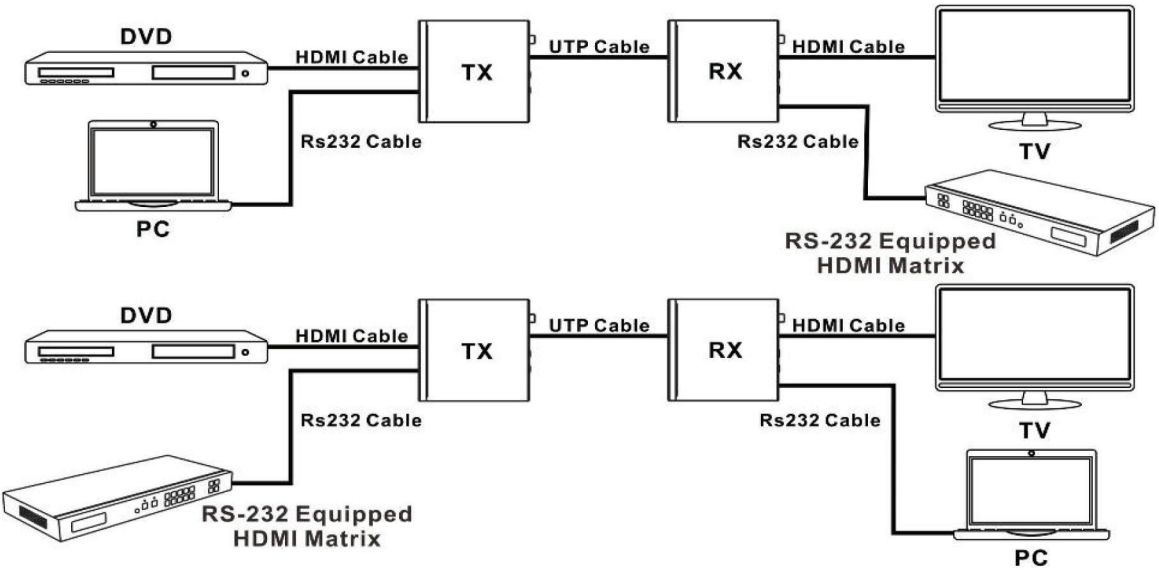

Preparing RS232 Cable

What you will need:

- A two-conductor cable with ground terminated with DB9 connectors or not
- Wire strippers
- Screwdriver (flat head)
- 3.5mm captive screw connector with 3 positions (included with plate)
- Heat gun and heat shrink (optional)
- Multimeter (optional)

Depending on your setup, you will need an RS232 cable with terminal block on one end to connect to the unit and either another terminal block or DB9 on the other side. The focus of this section will be on terminating the terminal block side with the proper pinout because that is what is connected to the unit. The other end of the cable is dependent on what the unit is connecting too, but all the information in this section will help to get the proper pinout in any case. As a tip, if connecting to a computer without a serial port, a USB to serial port converter can be used to communicate with RS232.

If the cable is terminated on both sides, start by cutting off the end that will be used for connecting to the unit. Then, strip the outer jacket of the cable back by about 1 inch like what is shown in Step 1 below. Once the outer jacket is removed, you can optionally add heat shrink around the conductors and over the exposed drain wire like in the picture of step 2. Next, strip the ends of the conductors back about 3/16" in order to make good contact inside of the captive screw connector. The final step is to attach the captive screw connector to the end of the cable matching the conductors on the other side of the cable to what is shown in step 3, use the connectors shown in the following figure as a reference if using DB9 male or female. Test the conductors with a multimeter to confirm termination.

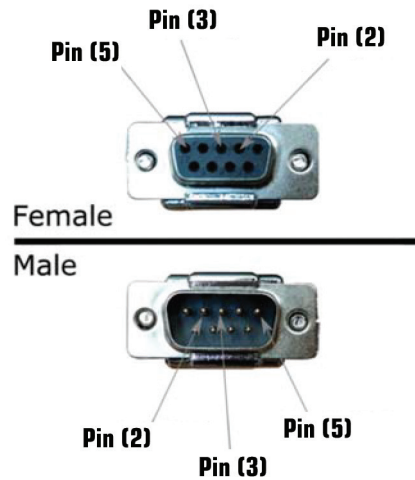
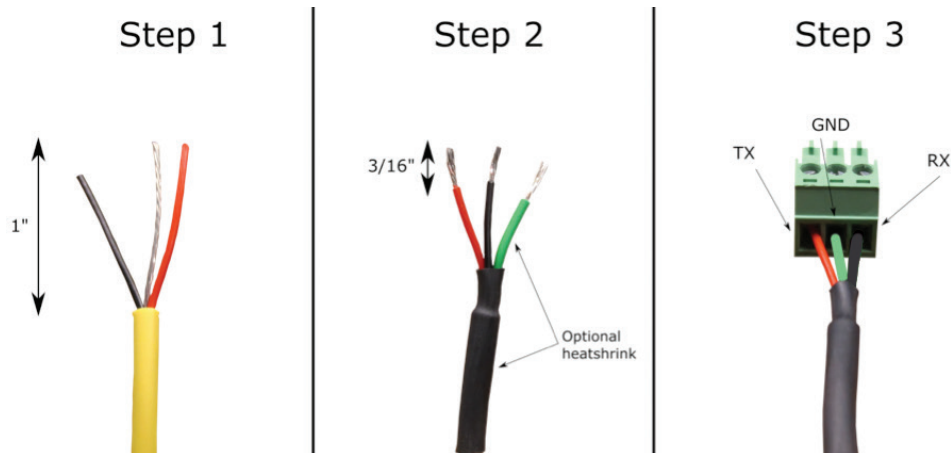

NOTE:

When using the device for pass-through, keep in mind that the side (either Tx or RX) that is connected to the device that the commands are getting sent to will require that the Tx and Rx pins get swapped around (serial null modem wiring). This means pin 2 of the DB9 connector will connect to the Rx pin of the HDBaseT device and pin 3 of the DB9 connector will connect to the Tx pin of the HDBaseT device.

RS 232 Application Example

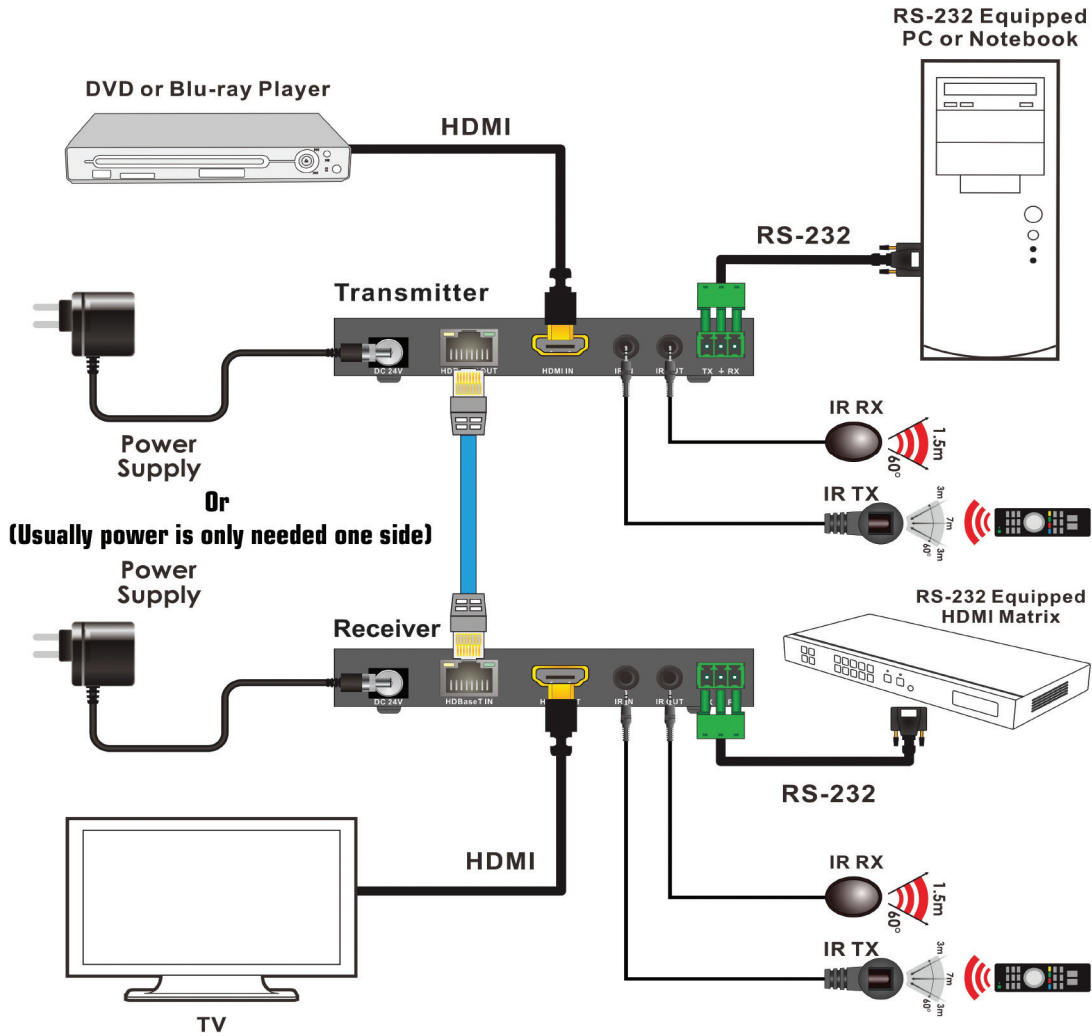

EHB-100

Warranty

Parts and labor warranty time is three year and from the date of original shipment. This warranty shall be void if a serial number has been removed from the product.

Upon determination of a legitimate defect covered by this warranty and at COVID's sole discretion, user should bear the transport cost during the warranty.

If product is out of warranty then repair charge is required. Out of warranty repairs will only be made after cost has been approved by Customers and proper financial arrangements are made. Customer must cover round trip shipment expenses.

Safety Information



To reduce the risk of electric shock, do not expose this product to rain or moisture.



Do not modify the wall plug. Doing so will void the warranty and safety features.



If the wall plug does not fit into your local power socket, hire an electrician to replace your obsolete socket.



This equipment should be installed near the socket outlet and the device should be easily accessible in the case it requires disconnection.

EHB-100